

# ESS<sup>®</sup>

## HOME / INDOOR Energy Storage System





# INDEX

NO.	SPEC. DESCRIPTION	
	System Architecture	3
	Cabinet	4
	HBI® Hybrid PV Inverter	6
	Battery	14
	essMoni® Monitoring	21

# HOME / INDOOR Energy Storage System

a turnkey home indoor power solution

JDA's advance technologies in planning, designing and engineering, for a safe and available power solution.

VDE0126  
 IEC62109-1-2  
 EN61000-6-2(EMC)

**KEY POINTS**

- ✓ SOLAR OPTIMIZING
- ✓ GRID INTERACTIVE
- ✓ PRICE RESPONSIVE
- ✓ DEMAND RESPONSIVE

### Brief Specification

- Battery Energy (kWh) : 4.9 / 9.8 / 14.7/19.6
- PV Inverter : 3/5 (kW)

### Renewable Value Enhancement

- JDA's **HBI**® provides a number of different features. Its peak shaving function allows the user to save electricity expenses by utilizing stored energy at peak times. The functionality which allows the integration with various renewable energy sources is one of the key advantages.

### Application

- Peak Load Shaving : Programmable energy control plans to optimizes peak load reduction.
- Off-Grid ESS: Stand-alone type in islanded micro-grids
- Demand Response : Targeted energy dispatch upon demand response signals.
- Voltage Support : Grid and critical load voltage support in response to low-voltage events.

### General Characteristics

- The next generation, Li-Polymer battery technology has a cycle life of > 4,000 cycles (@ 85% DOD, RT). Integrated with a highly efficient power conversion system (PCS) includes a charger, inverter, solar inverter, battery pack, and an Energy Management Software (EMS).

### Reliability

- The BMS is designed to ensure the safety by managing the operation modes in the most effective way.

### Software

- Control of **essMoni**® units in real-time including the ability to execute algorithms that automatically operate each battery as a fleet according to utility's preferences.

## System Technical Data



# Cabinet Solution

## General Properties & Dimension

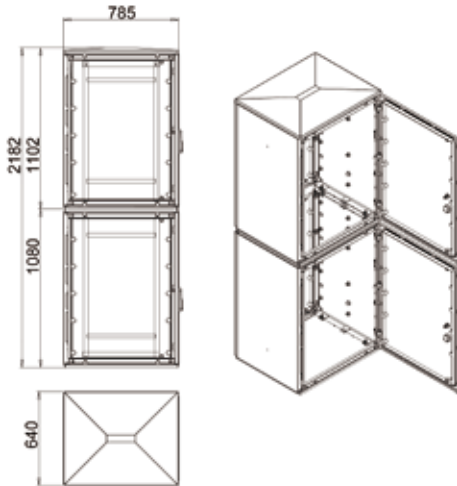

■ **Cabinet Size:**

785W x 2182H x 640D mm

■ **Protection level:**

IP65 according to IEC 529,  
BS EN 60529:1992 Certified,  
NEMA 4X and lower

■ **IP-66/65-55 & Lower:**

BS EN 60529:1992 Certified,  
NEMA 4X and lower



**GRP**

**GRP**

**Steel**

Test	Norm	Unit	
Young's modulus	DIN EN 527-4	GPa	12
Tensile strength	DIN EN 527-4	MPa	62
Flex strength	ISO 14125	MPa	150
Flex modulus	ISO 14125	GPa	10
Input strength	ISO 179	kl/m <sup>2</sup>	>68
Volume resistivity	IEC 60093	Ohm/cm	1.00e+15
Surface resistivity	IEC 60093	Ohm	1.00e+13
Tracking index	IEC 60112	Stufe	CTI600
Dielectric Strength	IEC 60243.1	kV/cm	240
Dielectric constant	IEC 60250	4	
Dissipation factor	IEC 60250	Tan Delta	0.01
Water absorption	ISO 62	mg/4d	45
Surface resistance	IEC 60093	Ohm	>10 12
Dielectric resistance	IEC 60243)	kV/mm	>18
Stability by light	Din EN ISO 877	7 - 8	
Tropical and moisture resistance	IEC 60068-2-5 ed. 69		without any degradation Stability of shape
Stability of shape	ISO 75(equiv.DIN 53462)		>200°C
Temperature resistance continuously		°C	-50 +- 150 Flame resistance
Flame resistance	UL 94 V0	mm	4

# Rack Solution

## General Properties & Dimension

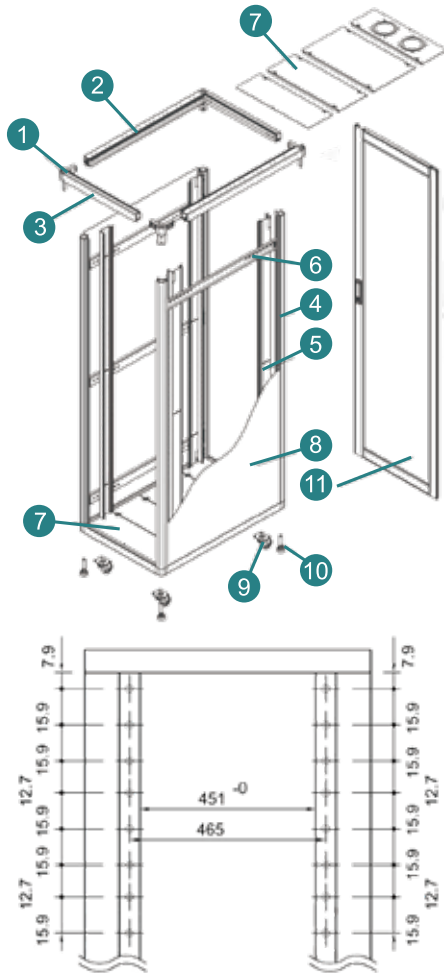

**ANSI/EIA-RS-310-D** 1U=1.75inches=44.45mm

(Unit:mm)

型號 MODEL No.	內部可用高度 Usable height	外部總高 (含輪子) Exremal Height	外部總高 (不含輪子) Exremal Height	深度 Deqth	外部寬度 External width	U數 U
R-156060-19	669	842	765	600	600	15
R-157560-19	669	842	765	750	600	15
R-159060-19	669	842	765	900	600	15
R-1510060-19	669	842	765	1000	600	15
R-1511060-19	669	842	765	1100	600	15
R-206060-19	892	1065	987	900	600	20
R-207560-19	892	1065	987	750	600	20
R-209060-19	892	1065	987	900	600	20
R-2010060-19	892	1065	987	1000	600	20
R-2011060-19	892	1065	987	1100	600	20
R-306060-19	1336	1509	1432	600	600	30
R-307560-19	1336	1509	1432	750	600	30
R-309060-19	1336	1509	1432	900	600	30
R-3010060-19	1336	1509	1432	1000	600	30
R-356060-19	1558	1731	1654	600	600	35
R-357560-19	1558	1731	1654	750	600	35
R-359060-19	1558	1731	1654	900	600	35
R-3510060-19	1558	1731	1654	1000	600	35
R-3511060-19	1558	1731	1654	1100	600	35
R-416060-19	1825	1998	1921	600	600	41
R-417560-19	1825	1998	1921	750	600	41
R-419060-19	1825	1998	1921	900	600	41
R-4110060-19	1825	1998	1921	1000	600	41
R-4111060-19	1825	1998	1921	1100	600	41
R-4112060-19	1825	1998	1921	1200	600	41
R-427560-19	1869	2042	1965	750	600	42
R-429060-19	1869	2042	1965	900	600	42
R-4210060-19	1869	2042	1965	1000	600	42
R-4211060-19	1869	2042	1965	1100	600	42
R-4212060-19	1869	2042	1965	1200	600	42

標準配備 Accessories of stander model		(Unit:mm)	
項次 No.	品名規格 Item	材質 MAterial	數量 Q.ty.
01	三向接頭 3D -die-casting corner	鋁合金 AL.(ADC 12)No.	8
02	框結構鋁柱 Frame member(A)	鋁合金 AL.(A6063 T5)	4
03	框結構鋁柱 Frame member(B)	鋁合金 AL.(A6063 T5)	4
04	主鋁柱 Main post	鋁合金 AL.(A6063 T5)	4
05	活動柱 Moceable mouting post	SPHC/SPCC ,t=2.0mm	4
06	定位軌 Horizontal Strut	SPHC/SPCC ,t=2.0mm	4/6
07	上(下) 蓋板 Top (Bottom) Plate	SPHC/SPCC ,t=1.6mm	配滿 (Filled)
08	固定式側板 Fixd Side Panel	SPHC/SPCC ,t=1.2mm	2
09	2.5c活動輪 Swivel Caster	P.U & Steel	4
10	地平螺絲 Floor Standa	Steel	4
11	後門組 Rear Door	鋁合金AL(A6063 T5) + SPCC,t=1.2mm	1

● 有標準庫存 ● 接單生產 ● 顏色：冷灰色/黑色 ● 可接受其他尺寸訂製

# Scheme & Single diagram

## Scheme Diagram

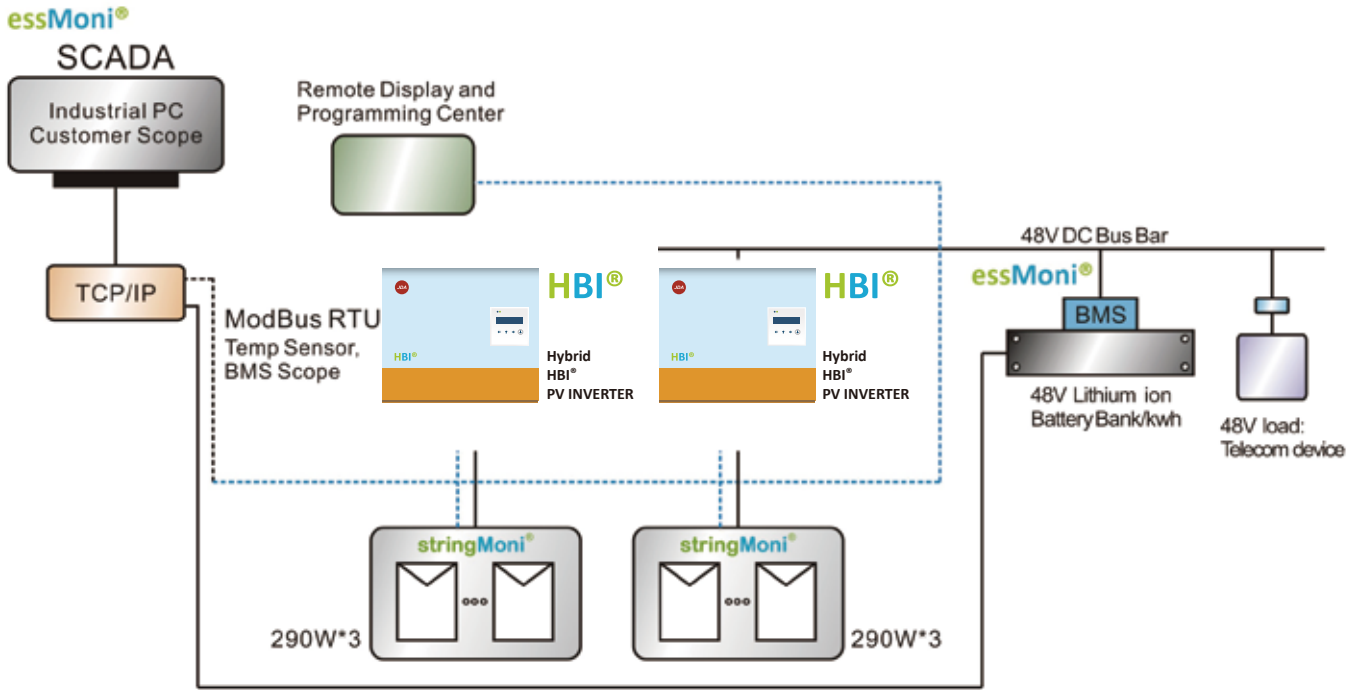

## Single Diagram

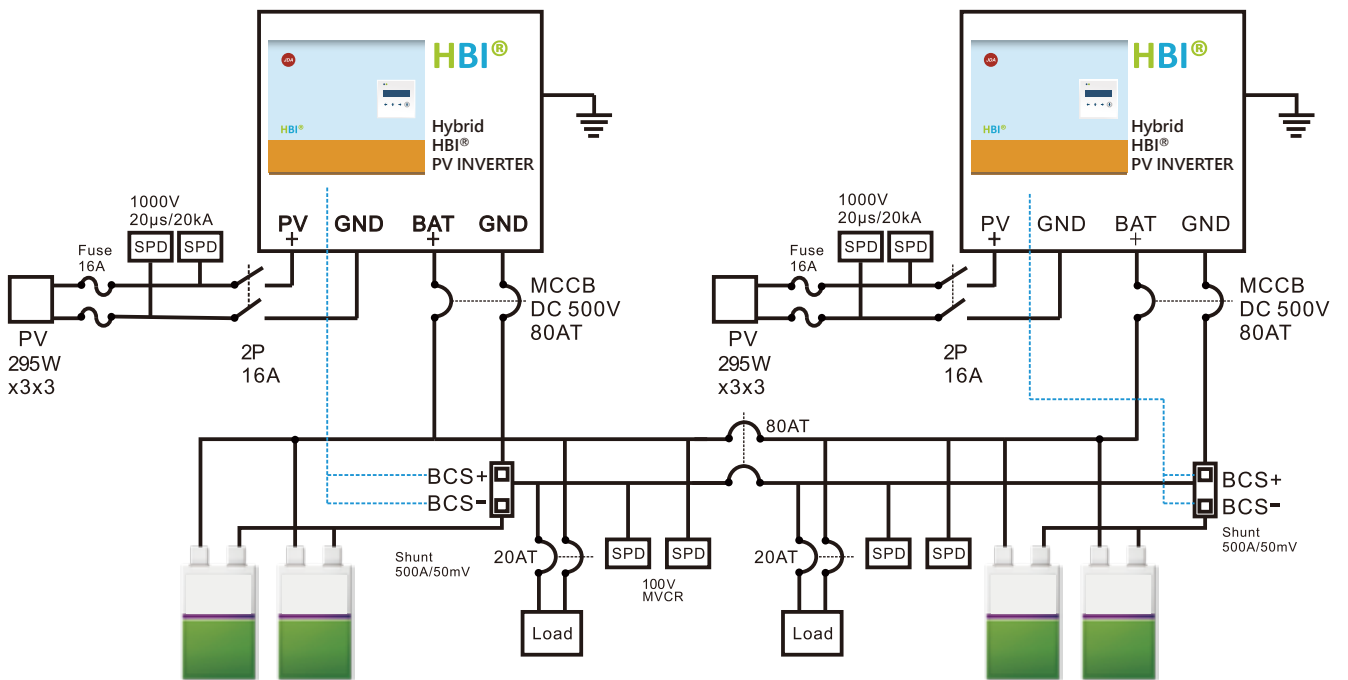



## PV Inverter Specifications

Model		HBI-3000-E-xx*	HBI-5000-E-xx*	HBI-5500-E-xx*
<b>Input (PV)</b>		<b>Unit</b>		
Max. PV Power	W P	3000	5000	5500
MPPT Range <sup>1</sup>	V	150~450	150~450	120~450
Max. DC Voltage	V	500	500	500
Max. Current	A	10	20	2/2*13
<b>Input (AC)</b>		<b>Unit</b>		
Nominal Voltage, Frequency	V/Hz	230,50/60		
Maximum Current	A	15	25	23.9
<b>Battery</b>				
Nominal Voltage	V	48	48	48
Max. Charging I Current	A	40	40	40
<b>Output (AC)</b>				
Nominal Power	W/VA	2400/3000	4000/5000	4000/5500
Nominal Voltage, Frequency	V/Hz	230,50/60		
Over-Load Capacity	%	200		
Waveform		Pure Sinusoidal		
Regulation (Linear Load)	%	±2		
<b>General</b>				
Temperature Range <sup>2</sup>	°C	-20~55		
Environment		Indoor		
Cooling		Forced Air - Coolinh		
Humidity	%	0~95, non-condensing		
Battery Type		VRLA or LiFePO 4		
UPS Function		Yes. Transfer time <4ms <sup>3</sup>		
Parallel Operation		No	Yes	No
<b>Interface &amp; Mechanical</b>				
Display		16 x 2 Test Display		

Note : 1. Input power maybe reduced for VPV <265V 2.AC power may need to be reduced for T>40°C  
3.Valid for single unit operation 4.Design to meet 5. Specifications are subject to change without prior notice  
\*stanealone - SA.  
Optional 1 : 80A, Optional 2 : 120A





## Specifications

Item	Model <sup>2</sup>	Unit	HBI-3600H	HBI-5000H	HBI-6000H
<b>Input (Mains, AC)</b>					
Nominal Voltage		V		230	
Voltage Range		V		190 ~ 300	
Nominal Frequency		Hz		50/60	
Power Factor				0.99	
Maximum Current		A	15	25	25
Inrush Current		A/μS		100/200	
Max. Power		VA	3300	5500	5500
<b>Input (PV, DC)</b>					
Maximum Power		W	3600	5000	6000
Maximum Voltage		V	550	500	500
MPPT Range <sup>3</sup>		V	100~500	100~450	100~450
Start-up Voltage		V	150	150	150
Maximum Current		A	10	20	10x2
Absolute Max. Current (Isc)		A	15	30	15
MPP tracker No.			1	1	2
Max. Backfeed Current		mA	1.6	1.6	1.6
<b>Battery I/O (DC)</b>					
Nominal Voltage		V		48	
Voltage Range		V		40~59	
Nominal Current		A	70	116	116
Maximum Current		A	90	150	150
Max. Charge Current <sup>4</sup>		A	60	80	100
Max. Leakage		mA		1	
<b>Output (Load, AC)</b>					
Nom. Power		VA	3000	5000	5000
Max. Power		W	3000	5000	5000
Inrush Current		A/μS	100/200	100/200	100/200
Max. Fault Current		A	50	79	79
Max. Protection Over-current		A	50	79	79
Nominal Voltage		V		230	
Nom. Frequency		Hz		50/60	
THDV		%		5	
Voltage Regulation		%		2	
DC injection		mV		±100	
Overload Capacity				600 seconds for 100% ≤ load ≤ 110% 30 seconds for 110% < load ≤ 150% 10 seconds for 150% < load ≤ 200%	
<b>General</b>					
Temp. Range		°C		-20 ~ 55°	
Max. Eff. (PV/AC)		%	96	96.5	96.5
Max. Eff. (BAT/AC)		%	92	92	92
Protection				IP20	
Humidity		%		0~95, non condensing	
Cooling				Forced Air-cooling Variable fan speed control	
Protection Class				I	
Environment Cat.				Pollution Degree III	
Overvoltage Cat.				DC input: II, AC input: III	
Amplitude		m		<2000	
Reconnect Time <sup>6</sup>		S		300	
<b>Features</b>					
LCD				2-line 16 characters text	
Interface				USB, RS485 & CANbus for multiple-unit operations	
RS485				2 wires, half-duplex	
Date Logging				Yes	
Parallel Operation			Yes	No	Yes
Max. Units for Parallel Operation			6	NA	6
Max. Units for 3-phase connection			9, 3 units in each phase	NA	9, 3 units in each phase





## Specifications

Item	Model <sup>2</sup>	Unit	HBI-3600H	HBI-5000H	HBI-6000H
<b>Mechanical</b>					
W x H x D		mm	580 x 408 x 168, wall mount models 490 x 165 x 580, rack mount models		
Weight		kg	22	23.8	24.2
DC switch			Optional <sup>7</sup>		
<b>Compliance</b>					
Grid Monitoring <sup>8</sup>			VDE0126-1-1/A1 IEEE 519 CEA (2013), IEC 61727, IEC 62116		
Safety			IEC 62109-1, 62109-2		
EMC Emission			EN61000-3-2, EN61000-3-3	EN61000-6-4, EN61000-3-11, EN61000-3-12	
EMC Immunity			EN61000-6-2		
<b>Battery</b>					
Capacity			100Ah/12V x 4 per bank		
Official Type			Refer to table below		
<b>Coding rule</b>					

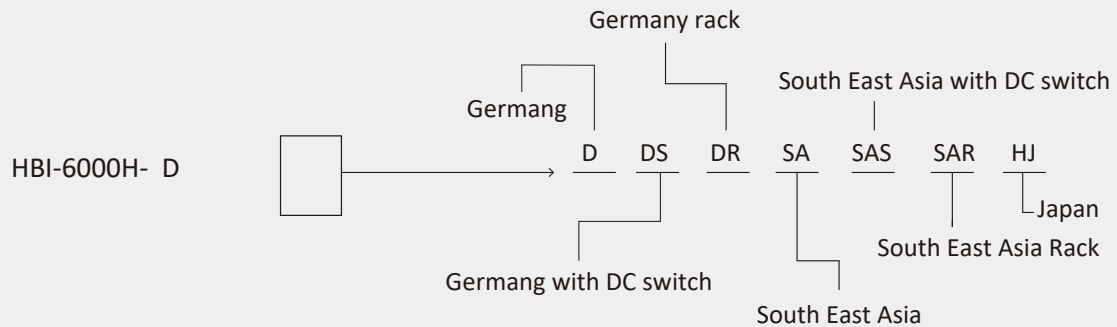

### Note:

1. Specifications are subject to change without prior notice
2. There are some variations for each model. Models with suffix “-SA” are off-grid; with “-D” are hybrid models with grid connection capability
3. The input power may be reduced for voltage lower than 250V
4. Charge current will adjusted according to battery configuration
5. Output power may be reduced for temperature > 40°C
6. Only for on-grid mode
7. For models with “/S” appended to normal model names
8. For –D models

# HBI-7500H-J

## Introduction

This product is designed for **ESS\***  
 (Energy Storage System) for Japanese market.

## Features

1. Split phase output
2. Grid-tie and off-grid modes
3. 200% surge power for load
4. All-in-one (Inverter and charge/discharge controllers)
5. Design for Lithium-ion, LiFePO4 batteries
6. Robust design, suitable for high temperature and humidity environments
7. High efficiency

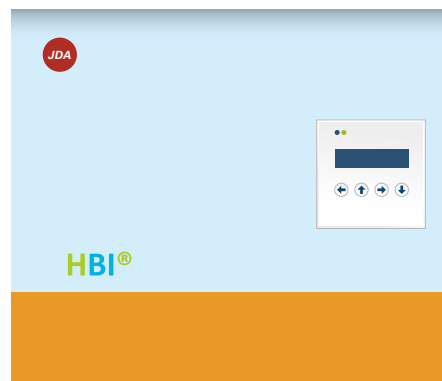

## Specification (Basic)

Item	Unit	HBI-7500H-J
<b>Input (PV)</b>		
Max. Power	W	7500
MPPT Range	V	150~450
Max. DC Voltage	V	500
Max. DC Current	A	30
MPPT Tracker		1
<b>Input (AC)</b>		
Nominal Voltage	V	100/200
Frequency	Hz	50/60
Max. Voltage	V	300
Max. Current	A	25
<b>Input (Battery)</b>		
Nominal Voltage	V	48
Operation Range	V	40 ~ 62
Nom. Current	A	90
Max. Current	A	110
<b>Output (AC, Grid-tie)</b>		
Nominal Power	W	5000
Nominal Frequency	Hz	50/60
Nominal Current	A	25
Max. Current	A	30
Voltage Range	V	Comply with JEAC 9701-2016
<b>Output (AC, Backup)</b>		
Nominal Power	W/WA	5000/5000
Voltage	V	101/202
Waveform		Pure Sinusoidal
Overload Capacity	%	200
Voltage regulation	%	± 3
<b>Output (Battery)</b>		
Max. Charging Current	A	80
<b>General</b>		
Temp. Range	°C	-10~50
Environment		Indoor
Cooling		Forced air-cooling
Humidity	%	0~95, non condensing
Transfer Time	mS	4
<b>Interface &amp; Mechanical</b>		
Display		2 LED, Green and Red 16 x 2 LCD text display
Comm. Interface		RS485, USB
Wireless		N/A
DC Switch		N/A
Orientation		Rack-mount
Dimension (W x H x D)	mm	490 x 133 x 450
Weight	kg	18
Protection Degree		IP20, indoor
<b>Compliance</b>		
Safety		JIS C 4412-1:2014, JIS C 4412-2:2014
Grid Monitoring		JEAC 9701-2016
EMC		JIS C 4411-2:2007

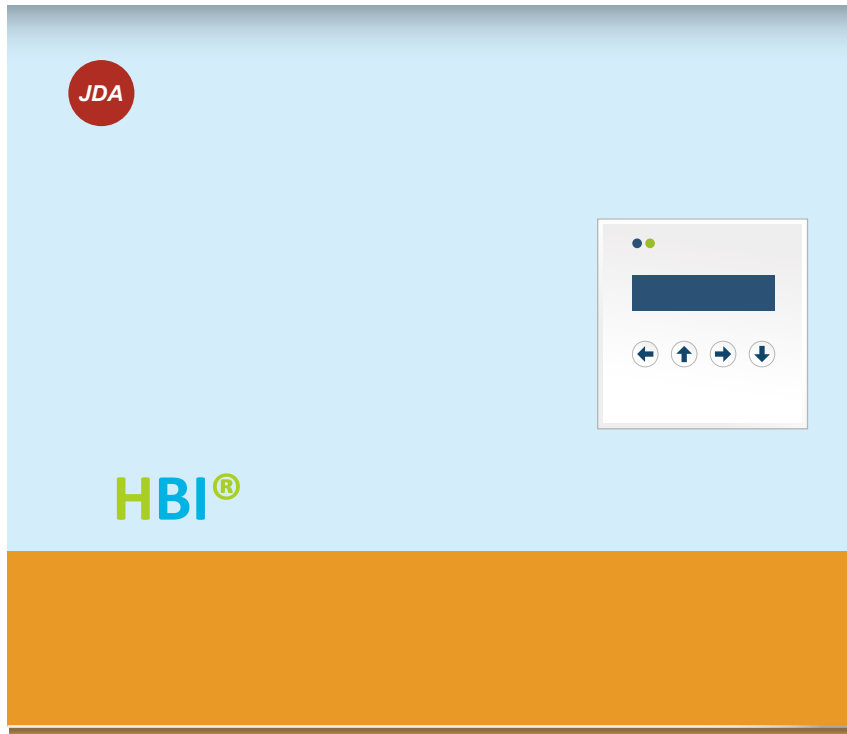

## Hybrid HBI® PV INVERTER

## Standalone

### Economically powerful solution for Photovoltaic and Storage

#### FEATURES

- Best CP value
- All-in-One
- 96% Conversion Efficiency
- Standalone/Grid Interactive
- 60A Charging Current
- 200% Overload
- Wall or 19" mount optional
- Net-metering & Self-use
- Operation without Battery
- UPS Function
- VRLA, LFP/NMC, CNT Batteries & Others
- High Temp. & Humidity
- Parallel Operations
- Cloud Monitoring (Optional)

**Operation Modes**

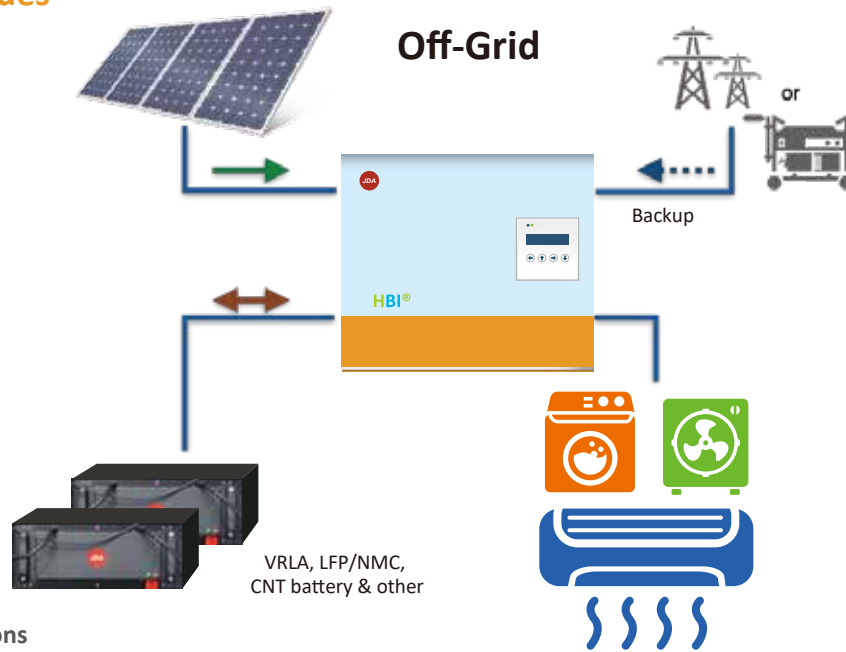

**Operations**

- AC grid or genset acts as a backup source
- Inverter supplies loads from PV and/or batteries
- Surplus PV power charges batteries
- Loads will be switched to backup input automatically while needed

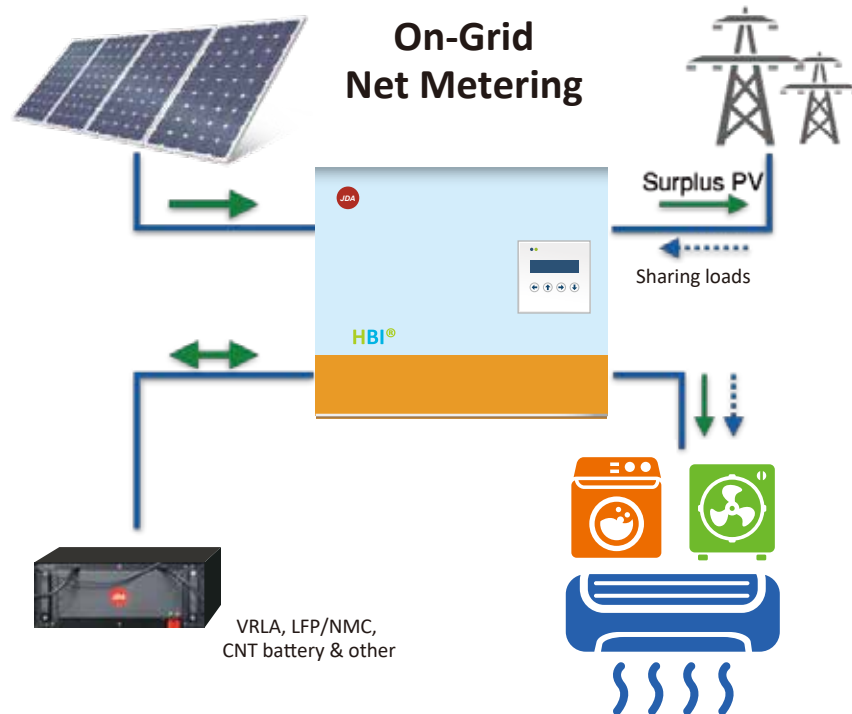

**Operations**

- Inverter output is physically connected to grid AC
- Inverter supplies loads from PV and/or batteries
- Extra PV power charges batteries and/or feeds grid
- Inverter and grid AC power loads together

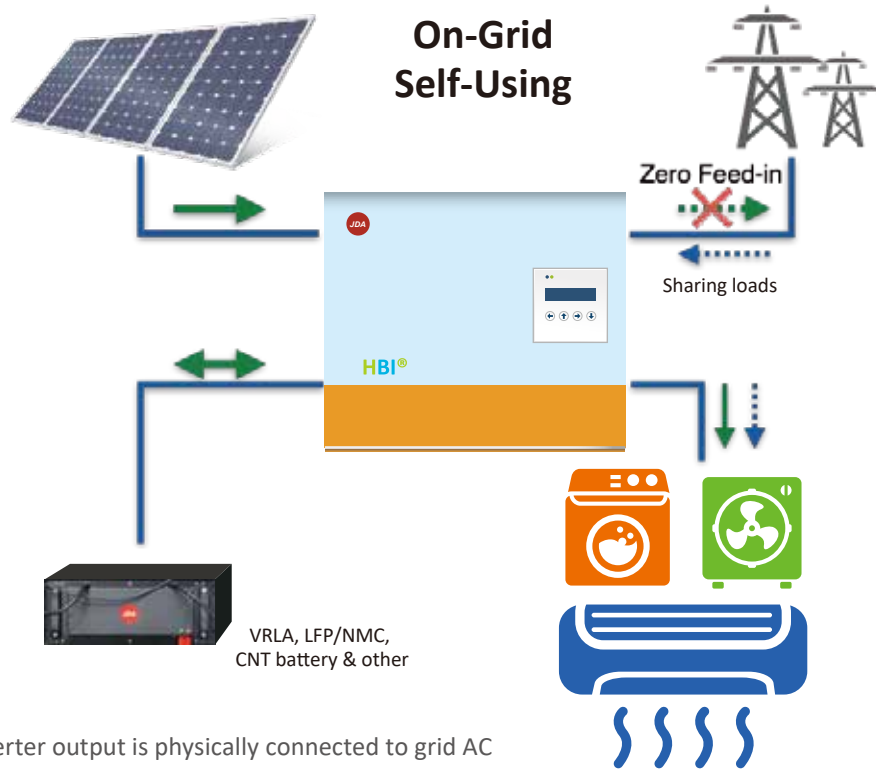

**Operations**

- Inverter output is physically connected to grid AC
- Inverter supplies loads from PV and/or batteries
- Extra PV power charges batteries
- Zero feeding to grid
- Inverter and grid AC power loads together

**Multi-unit System**

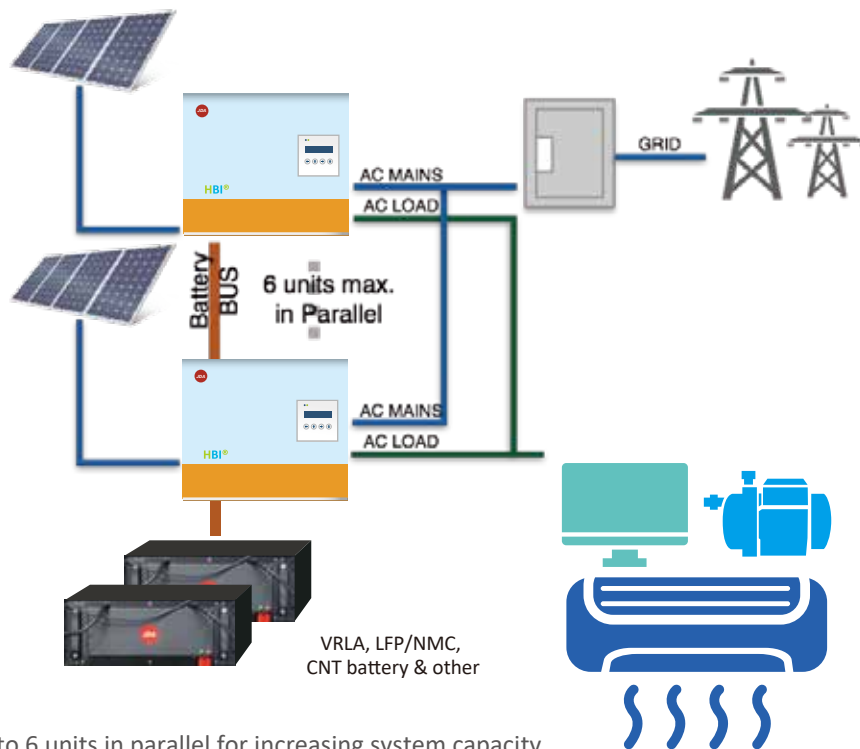

**Features**

- Up to 6 units in parallel for increasing system capacity
- Inverters share same battery bank
- Inverters power common loads
- Off-grid or on-grid mode



# Battery Bank

## Specification

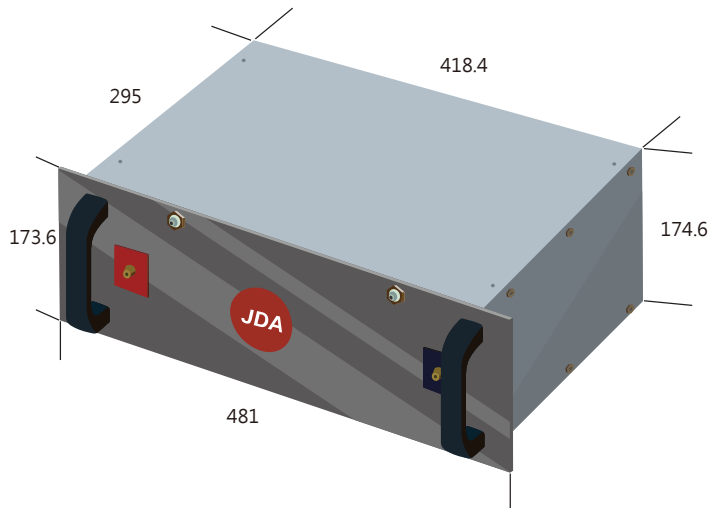

### Battery Specification

<b>Model</b>	JMP-2
Energy [ kWh ]	4.9
Nominal Voltage [V]	51.1
Voltage Range [V]	39.2~58.8
Nominal Capacity [ Ah ]	96
Max Discharge Current [ Amp ]	48
Discharge Current [Amp]	48
Charge Voltage [ V ] Max	58.8
Cell Type	Pouch
Chemistry	LiCoxNiyMnzO
Dimensions (LWH)) [ mm/inch ]	482(L) x 175(W) x 339(H)mm (±3mm)
Weight [ kg ]	36.3

### Performance

Cycle (0.2 charge and 0.2C discharge)	>4000 cycle 85%DOD,Temp 25~35°C
End of Life	80% SOC of 4000 cycle 85% DOD
Self-Discharge	TBD
Round Trip Efficiency	98.50%

### Operation Environments

Operating Temperture	0~50°C
Storage Temperture	-20~55°C
Humidity	RH45~85%

### Fornt Panel

Status Indicators	NA
SOC / ALM / RUN	NA
Protocol	RS485
Communication Ports	WP-04GF2-44 Waterproof Connector 4PIN(F)
Communicationin Parallel	Up to 6 trays

### Certification

IEC62133



# JDA JMP-□ Battery Pack Performance

## Battery module information and test conditions

### Battery module information:

- Battery Type: Lithium Polymer rechargeable cell
- Battery module : 14S2P
- Cooling type: Natural cooling

### Test conditions:

- Environment temp:25°C
- Initial temp:25°C
- 1C discharge: SOC 100% → 0%
- 2C discharge: SOC 100% → 0%

□ 1:Series connoction    2:Parallel

## SOC and voltage chart of 0.2C charge

0.2C 充電	
起始電壓(V)	45.553
容量(mAH)	87241.58
SOC	100%
最終電壓(V)	58.923

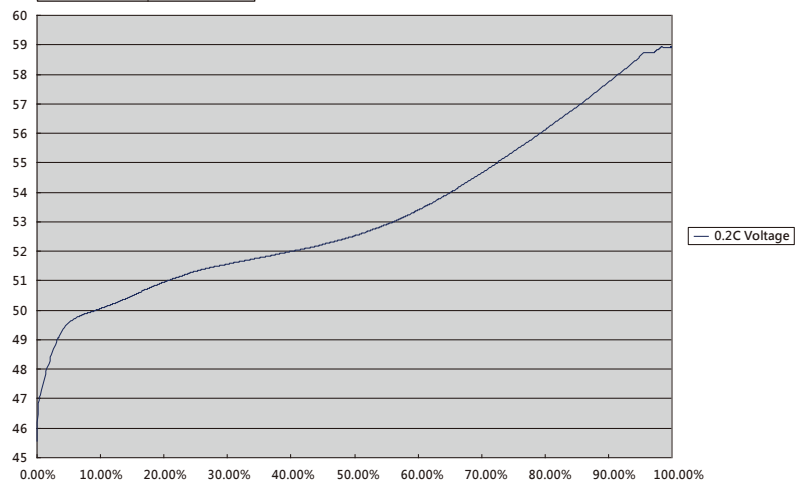

## SOC and voltage chart of different C-Rate discharge

	0.2C 放電	0.5C 放電	1C 放電	2C 放電
起始電壓(V)	58.86	58.04	58.63	58.44
容量(mAH)	87086	82867	82133	82167
SOC	100%	95.15%	94.31%	94.35%
最終電壓(V)	41.12	42.92	43.47	41.90

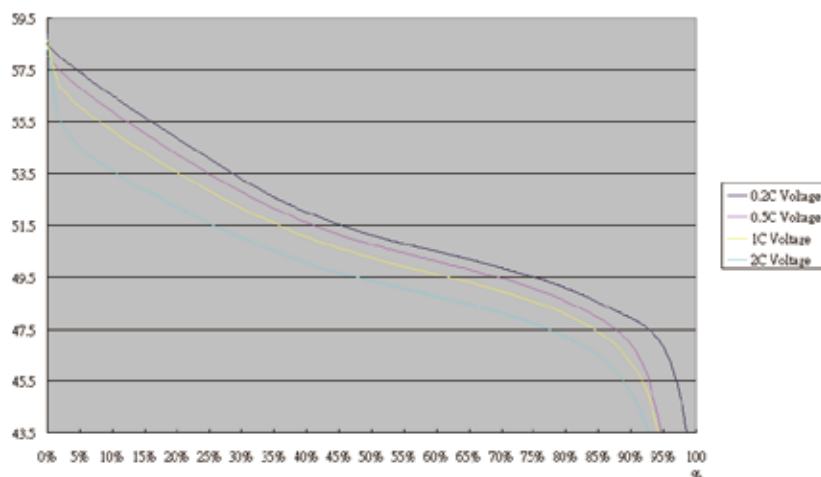



# Battery Cell

## Specification

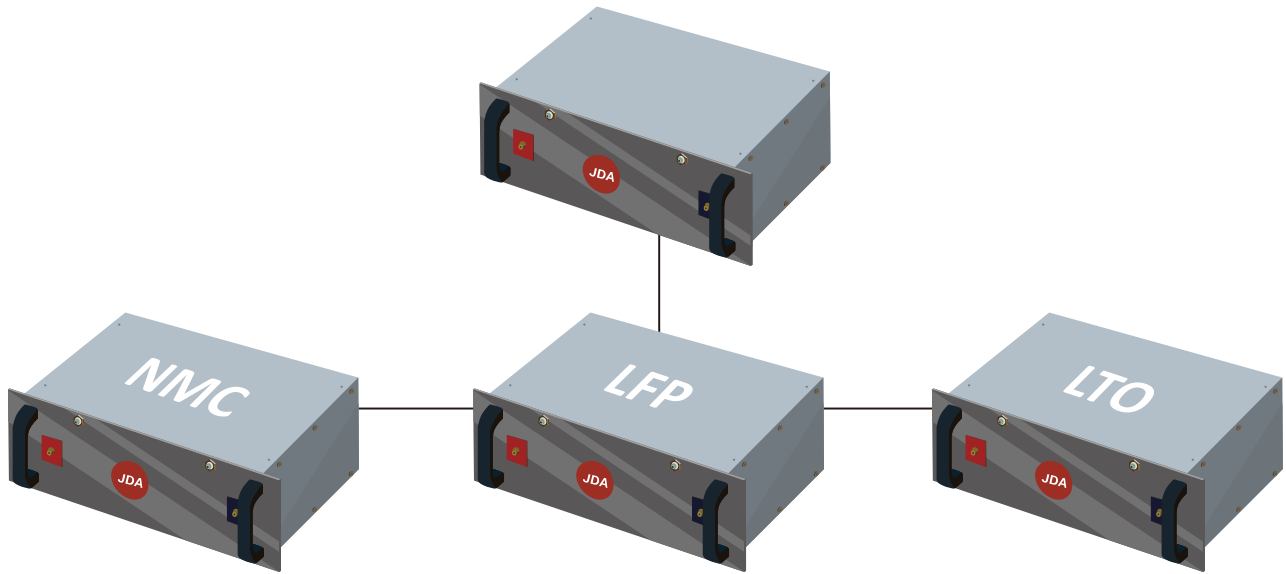

### Cell Specification

<b>Model</b>	JD44E
Capacity	Typical 50Ah / Minimum 48Ah
Chemistry	NMC (Optional : LFP / LTO )
Cell Voltage	Nomonal 3.65V
Charge Current	Charge 4.2V / Discharge 2.8V
Charge Time Standard	Standard 10A / Maximum 100A
Discharge Current	Standard 10A / Maximum* 100A
Internal Resistance	Ac (1KHz) < 1.0mΩ
Operating Temperature Charge	Charge 0°C~55°C / Discharge -20°C ~ 55°C
Energy Density	Volumetric ~ 417Wh/l
	Gravimetric ~ 207Wh/kg
<b>Certification</b>	UN38.3 / IEC62133

Material	Description	Chemical Formula
<b>NMC</b>	Lithium Nickel Manganese Cobalt Oxide	LiNixMnyCozO2
<b>LFP</b>	Lithium Iron Phosphate	LiFePO4
<b>LTO</b>	Lithium Titanate Oxide	Li4TI5O12



## PowerSave, Application Situation (Off Grid)

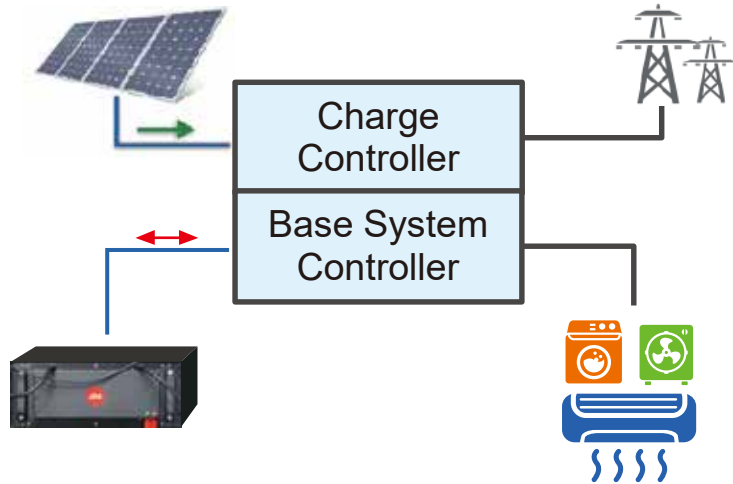

- Capacity: 4.2KWh \* 3 = 12.6KWh
- Input: 16 ~ 112v DC
- Inverter Output for Battery: 2 ~ 120v DC adjustable
- Input voltage: solar panel voltage
- Maximum charge current : 70A
- DOD ratio : 80%
- Battery module life cycle : 3000+ cycles & keeps above 60%
- 8 years: keeps 55+% capacity
- 0.2C discharge rate

AC power	Battery	solar power	load	Application features
power supply	FULL	FULL	power demand > solar power	Solar power will be the main power source to load and support the remaining power demand by the mains or battery.
power supply	FULL	FULL	solar power > power demand	Solar power will supply to load.
power supply	Half Full	FULL	power demand > solar power	Solar power will be the main power source to load and support the remaining power demand by the mains or battery.
power supply	Half Full	FULL	solar power > power demand	Solar power will be the main power source to load and charge battery.
power supply	Low	FULL	power demand > solar power	Solar power will be the main power source to load and support the remaining power demand by the mains or battery.
power supply	Low	FULL	solar power > power demand	Solar power will be the main power source to load and charge battery.
power supply	FULL	OFF	load	Use utility supply to load.
power supply	Half Full	OFF	load	Use utility supply to load and charge battery.
power supply	Low	OFF	load	utility supply to load , utility supply charging battery
power outage	FULL	FULL	power demand > solar power	Solar power will be the main power source to load and support the remaining power demand by the mains or battery.
power outage	FULL	FULL	solar power > power demand	Solar power will supply to load.
power outage	Half Full	FULL	power demand > solar power	Solar power will be the main power source to load and support the remaining power demand by the mains or battery.
power outage	Half Full	FULL	solar power > power demand	Solar power will be the main power source to load and charge battery.
power outage	Low	FULL	power demand > solar power	Solar power will be the main power source to load and support the remaining power demand by the mains or battery.
power outage	Low	FULL	solar power > power demand	Solar power will be the main power source to load and charge battery.
power outage	FULL	OFF	load	Use battery for the power supply.
power outage	Half Full	OFF	load	power by battery
power outage	Low	OFF	load	power by battery



## PowerSave, Application Situation (Grid Connected)

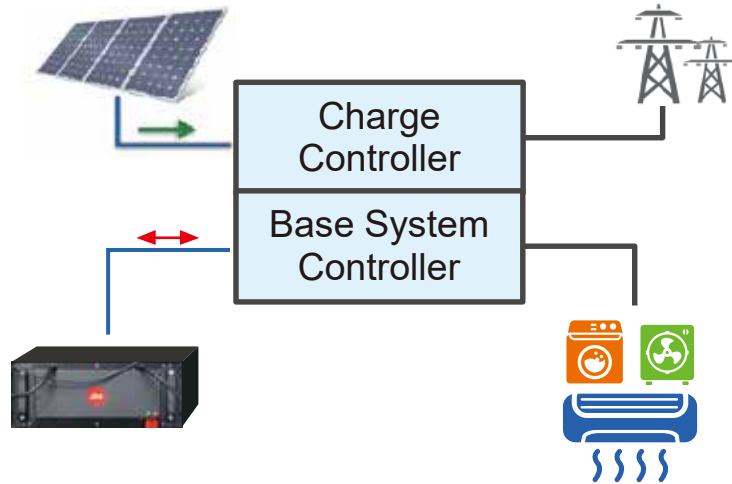

- Capacity: 4.6KWh \*3 = 13.8KWh
- Input: 16 ~ 112v DC
- Inverter Output for Battery: 2 ~ 120v DC adjustable
- Input voltage: solar panel voltage
- Maximum charge current : 70A
- DOD ratio : 80%
- Battery module life cycle :3000+ cycles & keeps above 60%
- 8 years: keeps 55+% capacity
- 0.2C discharge rate

AC power	Battery	Solar Power	Load	Application Features
power supply	FULL	FULL	power demand > solar power	Solar power will be the main powersourceto loadand support the remaining power demand by the mains or battery.
power supply	FULL	FULL	solar power > power demand	Solar power will supply to load.
power supply	Half Full	FULL	power demand > solar power	Solar power will be the main power sourceto loadand support the remaining power demand by the mains or battery.
power supply	Half Full	FULL	solar power > power demand	Solar power will be the main power sourceto loadand charge battery.
power supply	Low	FULL	power demand > solar power	Solar power will be the main power sourceto loadand support the remaining power demand by the mains or battery.
power supply	Low	FULL	power demand > solar power	Solar power will be the main power sourceto loadand charge battery.
power supply	FULL	OFF	load	Use utility supply to the load.
power supply	Half Full	OFF	load	Use utility supply to the loadand charge battery.
power supply	Low	OFF	load	Use utility supply to the loadand charge battery.
power outage	FULL	FULL	power demand > solar power	Solar power will be the main power sourceto loadand support the remaining power demand by the mains or battery.
power outage	FULL	FULL	power demand > solar power	Solar power will supply to load
power outage	Half Full	FULL	power demand > solar power	Solar power will be the main power sourceto loadand support the remaining power demand by the mains or battery.
power outage	Half Full	FULL	power demand > solar power	Solar power will be the main power sourceto loadand charge battery.
power outage	Low	FULL	power demand > solar power	Solar power will be the main power sourceto loadand support the remaining power demand by the mains or battery.
power outage	Low	FULL	power demand > solar power	Solar power will be the main power sourceto loadand charge battery.
power outage	FULL	OFF	load	Use battery for the power supply.
power outage	Half Full	OFF	load	power by battery
power outage	Low	OFF	load	power by battery



## Distributed Power Planet (Grid Connected)

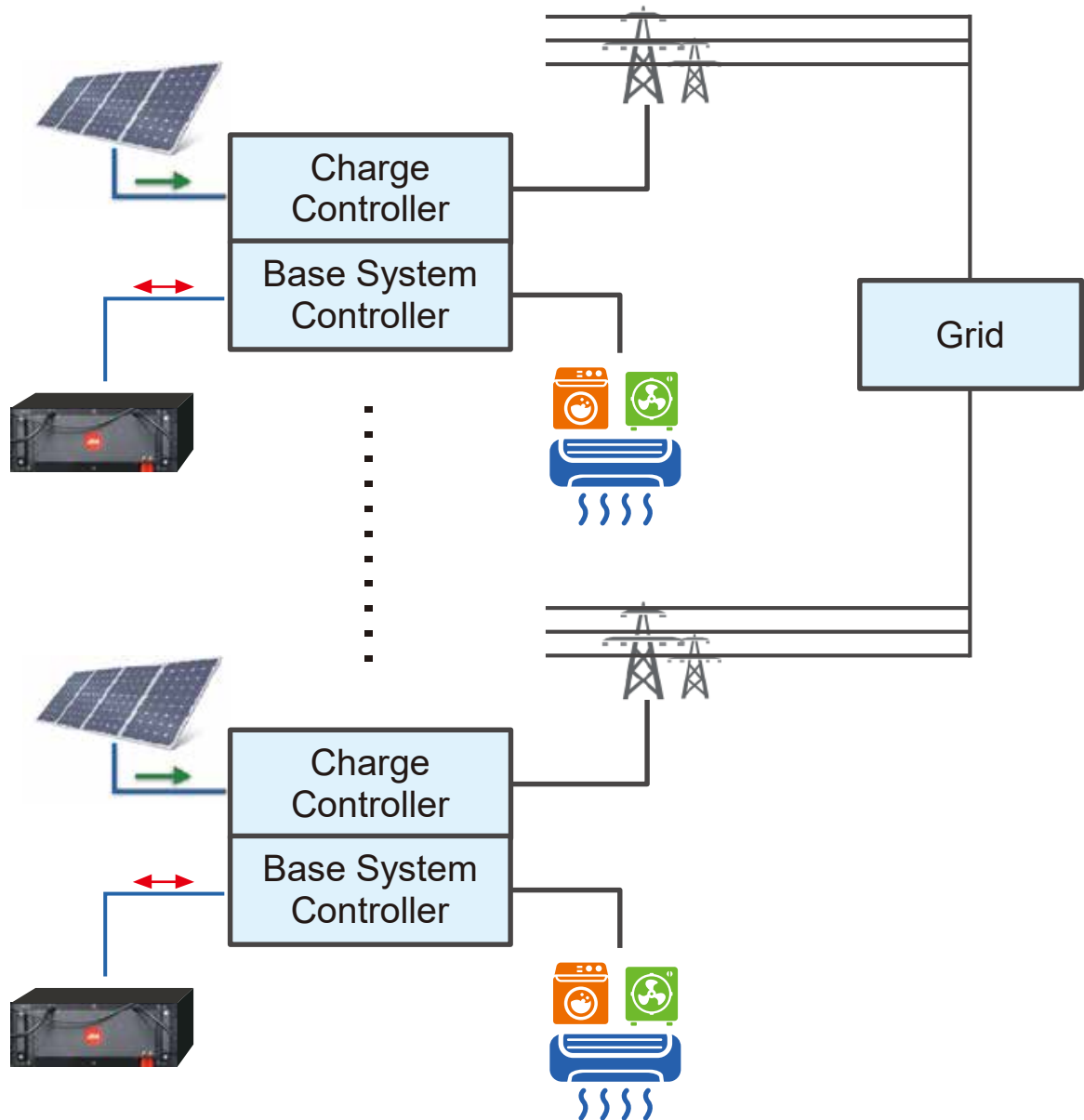

- Our system is able to create a distributed power planet.
- Assumption: there are 10 million home solar PV systems with 10KW solar power system each and it will generate 100 million KW for average 5.5 hours in Brazil.
- If there are 50% power will be unused and stored in PowerSave system, it will be 50 million KW will be stored in solar period of 5.5 hours. This means they system can support more than 1.5 times total power planet capacity within this 5.5 hours in Taiwan; equalvalent to a saving of construction cost in power planet of 1 billion USD.
- If each Powersave system can save 5KWh, it can save 250 million KWh, so this will be a good advantage for this system.



## JD44E

Battery Module		42 Ah
System		NCM
Capacity		42Ah
Nominal Voltage		3.65V
Charging Voltage		4.20V
Discharge Cut-off Voltage		3.00V
Charging Current	Standard charge	8.4 A
	Max charge	132A ( Instant charging )
Max. Continuous Discharge Current ( duration )		44A (Continuous) 132A(Continuous) 220A( Instant ,90S)
Battery Weight , energy density		< 947 g, 170.0 wh/kg
Battery Internal Impedance		≤ 1.2mΩ
Ambient temperature	charge	0~55°C
	discharge	-20~55°C
	storage	One month:-20°C~ 55°C Three months: -20°C~ 45°C Twelve months: -20°C~ 40°C
Cycle Life (0.1Ccharge -0.1Cdischarge) Ambient temperature : 25°C		4000 cycles/80%

## Enhanced JD44E Cell

Battery Module		47 Ah
System		NCM CNT enhanced
Capacity		47Ah
Nominal Voltage		3.65V
Charging Voltage		4.20V
Discharge Cut-off Voltage		3.00V
Charging Current	Standard charge	9.4 A
	Max charge	94 A ( Instant charging )
Max. Continuous Discharge Current ( duration )		47 A(Continuous) 141A(Continuous) 235A(Instant ,180S)
Battery Weight , energy density		< 940g, 188wh/kg
Battery Internal Impedance		≤ 1.0mΩ
Ambient temperature	charge	0~55°C
	discharge	-20~55°C
	storage	One month:-20°C~ 55°C Three months:-20°C~ 45°C Twelve months:-20°C~ 40°C
Cycle Life (0.1Ccharge-0.1Cdischarge) Ambient temperature : 25°C		6000 cycles/80%

# essMoni<sup>®</sup> Monitoring

## Monitoring System



### Solar Panel Input String Monitoring

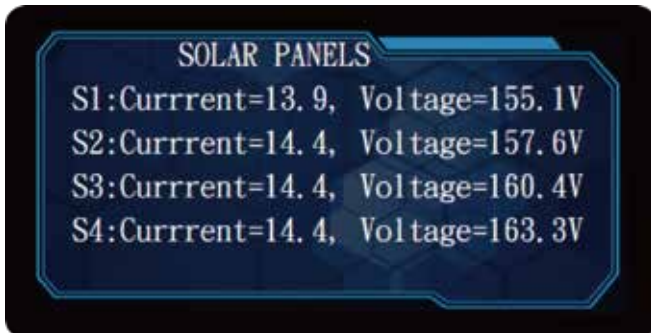

### INV monitoring integrated with stringMoni<sup>®</sup>

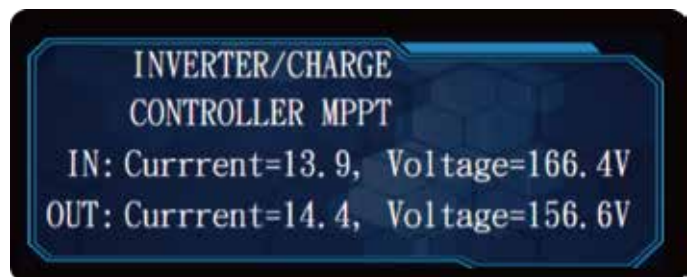

Detect INV DC IN DCV DCA  
 DC OUT DCV DCA

## Monitoring

PV Input, Output V, Output A, Today Amp Hour (Low/High record),  
 Today Watt Hour (Low/High record) Real Time Charge Status, MPPT Temp., NET Mode, Battery SOC, Battery Status (including V \ A \ Amp Hour \ Temp.), Shunt Connect Status, Voltage sensor Connect Status Local Server 20 years memory, 2 ModBus, 1 EtherNet, web page.



## Error Code



## Charge Controller



It can detect DC IN DCA DCV  
 Control battery charge and discharge

## BMS integrated with essMoni<sup>®</sup>

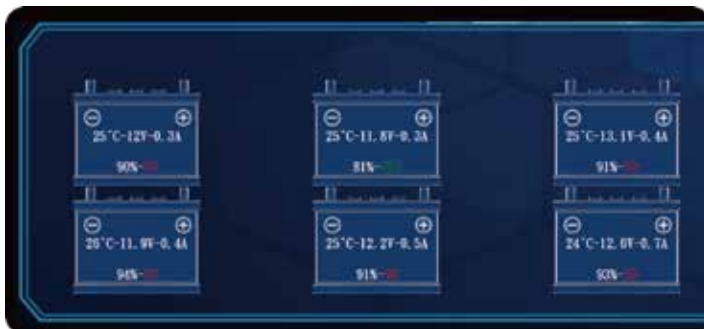

## ModBus access

- |                                 |                                  |
|---------------------------------|----------------------------------|
| 1.Input Voltage (PV Input)      | 11.MPPT Temperature              |
| 2.Input Current (PV Input)      | 12.NET Mode                      |
| 3.Output Voltage                | 13.Battery SOC                   |
| 4.Output Current                | 14.Battery Voltage               |
| 5.Today Amp Hour (Low 16bits)   | 15.Battery Current               |
| 6.Today Amp Hour (High 16bits)  | 16.Battery Amp Hour              |
| 7.Today Watt Hour (Low 16bits)  | 17.Battery Temperature           |
| 8.Today Watt Hour (High 16bits) | 18.Shunt Connect Status          |
| 9.Today FloatTime               | 19.Voltage sensor Connect Status |
| 10.Real time Charge State       |                                  |

## TCP/IP connection for different country, please specify

**SNMP NAT VPN Firewall**  
**Wireless 4G network card**





日揚國際事業股份有限公司  
JD Auspice Co., Ltd.

ESS<sup>®</sup>